

Structure of Macrozoobenthos Community in the Coastal Intertidal Zone, Marapalam South Coast Regency, West Sumatra

Dandi Asmawi^{1*}, Afrizal Tanjung¹, Syafruddin Nasution¹

¹Department of Marine Science, Faculty of Fisheries and Marine, Universitas Riau, Pekanbaru 28293 Indonesia
Corresponding Author: dandi.asmawi1123@student.unri.ac.id

Received: 6 April 2025; Accepted: 4 May 2025

ABSTRACT

Macrozoobenthos is a community of organisms that spend part or all of their life cycle on the bottom of the waters, either crawling, sessile, or digging holes. This study aims to analyze the structure of the macrozoobenthos community in the intertidal zone of Marapalam Beach, South Coast Regency, West Sumatra Province. Sampling was carried out at three stations. Station I (mangrove), Station II (tourist spot), and Station III (fishing boat). Macrozoobenthos sampling used the purposive sampling method. Macrozoobenthos sampling at the bottom of the waters using a shovel, the substrate was filtered using a 1 mm² mesh size sieve to separate the organism samples from the substrate. The results showed that the macrozoobenthos found on Marapalam Beach consisted of 2 classes and five families, five genera, and nine species of macrozoobenthos. The highest abundance of macrozoobenthos was found in the species *Clypeomorus batillariaeformis*. Diversity of research locations (H' 1.19), Dominance (C 0.17), Diversity (E 0.87), Clustered distribution patterns (Id 5.51), and similarity indexes of 71-100% are categorized as high species similarity.

Keywords: Macrozoobenthos Community, Marapalam Beach, Sampling

1. INTRODUCTION

Coastal areas play an essential role in human life, both in ecology and socio-economics. Based on Law of the Republic of Indonesia Number 1 of 2014 concerning the Management of Coastal Areas and Small Islands, coastal areas are transitional areas between land and sea ecosystems that are influenced by various factors such as tides, sea breezes, and saltwater infiltration (Pemerintah Indonesia, 2014). This area is a place for multiple human activities, which have the potential to reduce the quality of the aquatic environment and disrupt the balance of its ecosystem, especially in the intertidal zone.

The intertidal zone is the part of the coast between the highest and lowest tides. Although relatively narrow in area, this zone has a diverse ecosystem and supports the abundance and diversity of organisms (Nybakken in Zulfa, 2015). However, exploiting natural resources in this area can put significant ecological pressure, especially on macrozoobenthos. These organisms have an essential role in the food chain and balance of aquatic ecosystems and are a biological indicator in assessing water quality (Tobing, 2009).

Macrozoobenthos are widely distributed

in marine ecosystems, such as seagrass, coral reefs, mangroves, and sandy and muddy substrates (Rizkya et al., 2012). The existence and abundance of macrozoobenthos can reflect the condition of the aquatic environment in terms of physical, chemical, and biological aspects. Changes in water quality due to human activities can disrupt macrozoobenthos communities, ultimately impacting the coastal ecosystem as a whole. Macrozoobenthos is one of the biological aspects that play an important role in assessing the quality of water, including coastal waters (Ridwan et al., 2016).

Beach Marapalam, located in South Coast Regency, West Sumatra Province, is a coastal area with various human activities, including tourism, fisheries, and mangrove ecosystems. These activities have the potential to pressure the structure of the macrozoobenthos community in the area.

Although research on the structure of macrozoobenthos communities has been conducted in various regions, studies specifically researching macrozoobenthos communities in Marapalam Beach are still limited. Therefore, this study was conducted to identify the structure of macrozoobenthos communities in the intertidal zone of Marapalam

Beach.

Research on the structure of macrobenthic communities in the waters of various regions includes the diversity of macrobenthic communities as bioindicators of the quality of the Ranu Pani-Ranu Regulo waters in Bromo Tengger Semeru National Park (Ramadini, 2019). The diversity of macrobenthic communities as bioindicators of water quality in the Way Kedamaian River, Bandar Lampung (Afif et al., 2014). The results of research on the Structure of Macrobenthic Communities in the Intertidal Zone of Marapalam Beach, Pesisir Selatan Regency, West Sumatra Province, are expected to provide basic information for the management and conservation of coastal ecosystems in the area, as well as a reference for further research on coastal ecology in West Sumatra.

2. RESEARCH METHOD

Time and Place

This research was conducted in September 2024. Sampling was carried out in the intertidal waters of Marapalam Beach, South Coast Regency, West Sumatra Province (Figure 1). Furthermore, analysis and identification were conducted at the Marine Biology Laboratory, Department of Marine Sciences, Faculty of Fisheries and Marine Sciences, Universitas Riau.

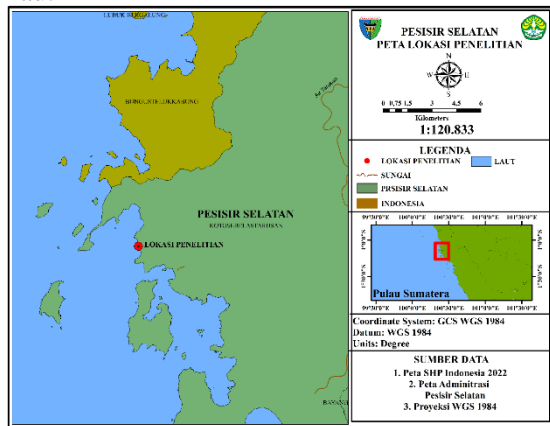

Figure 1. Map of research location

Method

The method used in this study was a survey method. The parameters of the macrozoobenthos community structure measured included macrozoobenthos abundance, relative abundance, diversity, distribution patterns, dominance, and species similarity. Meanwhile, the parameters of water conditions include temperature, pH, DO

(Dissolved Oxygen), salinity, current speed, brightness, sediment organic matter, and sediment fraction. Samples were taken three times directly in the field and at the Marine Biology Laboratory, Department of Marine Sciences, Faculty of Fisheries and Marine, Universitas Riau.

Procedures

Determining Research Locations

Determination of stations and sampling points was carried out using the purposive sampling method, where the determination of sampling points was based on the criteria of the area around the research site. The location of this study was divided into three stations based on the criteria, namely, Station I is in an area with mangroves, Station II is in an area without mangroves (tourist spot), and Station III is close to community activities that place. At each station, three transects were drawn with a transect line length of 5 m, with a distance between transects of 10 m. Then, each transect was installed with a plot measuring 1x1 m². The distance between zones is 1 m, from the lowest ebb point to the highest tide point. The length of the transect is determined from each location length from the shoreline to the ebb direction. Each transect has three sampling points: 1. In the intertidal zone, namely in the highest tide zone (upper zone), 2. in the zone between the highest tide and the lowest ebb (middle zone), 3. in the lowest ebb limit zone (lower zone). The research scheme can be seen in Figure 2.

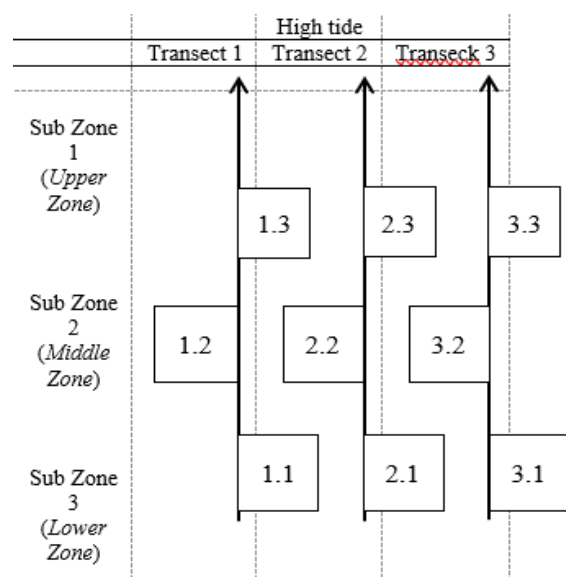

Figure 2. Schematic of transect and plot placement in the intertidal zone

Macrozoobenthos Sampling

Macrozoobenthos samples were taken using the quadrat transect method in different intertidal subzones, where each research station was divided into three subzones, namely: 1) upper intertidal zone, 2) middle intertidal zone, and 3) lower intertidal zone. Macrozoobenthos sampling was carried out at low tide to make it easier for researchers to sample. Sampling of macrozoobenthos using a shovel. Each type of macrozoobenthos has a different depth, and the substrate is filtered using a sieve of 1 mm² mesh size to separate the organism samples from the substrate. The filtering results are put into a sample plastic containing 10% formalin, labelled with information on the station's location, transect, plot, and sampling time, and then put into an ice box. Then, the samples were taken to the Marine Biology Laboratory of Riau University for identification.

Water Quality Measurement

Water quality measurements were conducted at each station in the intertidal zone of Marapalam Beach and were repeated three times. Data obtained from water quality measurements are considered to influence the macrozoobenthos community's structure significantly. The water quality measurements carried out consisted of current speed, salinity, temperature, acidity (pH), brightness, DO (Dissolved Oxygen), sediment organic matter, and sediment fractions, which were repeated 3 times to provide an overview of the water conditions at the time of the study.

Macrozoobenthos Sample Analysis

Macrozoobenthos samples brought to the laboratory were washed with fresh water, and then the macrozoobenthos were identified and grouped into trays labelled according to the station points. Samples were determined based on the shape obtained using an identification book (Carpenter & Niem, 1998). Then, the number of species obtained was calculated.

Abundance of Macrozoobenthos

The abundance of macrozoobenthos species is calculated by calculating the percentage of each species obtained during identification, namely by dividing the number of individuals per species by the total number of individuals. According to Brower et al. (1990), the abundance of macrozoobenthos is calculated using the following formula:

$$K = \frac{ni}{A}$$

Information:

- K = Abundance individual type I (ind/m²)
 ni = number of individuals of type i
 A = Area of plot type I found (m²)

Relative Abundance of Macrozoobenthos

The relative abundance of individual macrozoobenthos is calculated using the Cox formula (Alwi, 2020):

$$KR = \frac{ni}{A} \times 100\%$$

Information:

- KR = Relative abundance
 ni = Number of individuals of type i obtained
 A = Area of plot type i found (m²)

Biodiversity (H')

Species diversity is used to describe the state of a population in a place in a mathematical way that is useful for analyzing information on the number of individuals in a community to be easier. Then, the calculation is carried out using the Shannon-Wiener equation (Fachrul, 2007):

$$H' = - \sum_{i=1}^s pi \ln pi$$

Information:

- S = Number of types
 pi = The proportion of individuals of the i-th species to the total individuals of all species (pi=ni/n)
 ni = Total number of individuals of type i (ind/cm²)
 N = Total individuals of all types (ind/cm²)
 s = Number of species successfully captured
 ln = Natural logarithm

The Shannon-Wiener diversity index criteria (H') according to Setiawan & Maulana (2019) has a specific range of values, namely as follows: H' < 1 = The species diversity is low, the number of individuals per species is low, the community stability is low and the condition is heavily polluted; 1 < H' < 3 = Moderate diversity, moderate distribution of the number of individuals of each species and moderate water pollution; H' > 3 = High diversity, high distribution of the number of individuals of each species and unpolluted waters.

Dominance (C)

Dominance is a calculation used to obtain information on families that dominate a community. To calculate the dominance index using the Simpson formula (Odum, 1993), namely:

$$C = \sum_{i=1,2,3}^s \left(\frac{n_i}{N}\right)^2$$

Information:

- C = Dominance index
- s = Number of types successfully retrieved
- n_i = The number of individual types of type i (ind/cm²)
- N = Total number of individuals of all types (ind/cm²)

With the criteria: 0 < C < 0,3= Low dominance; 0,3 ≤ C ≤ 0,6 = Medium dominance; and 0,6 < C < 1 = High dominance

Homogeneity (E)

Uniformity is calculated using the formula according to Krebs in Fajri (2013), namely:

$$E = \frac{H'}{\ln S}$$

Information:

- E = Uniformity index of species
- H' = Species diversity index
- S = Number of species

The uniformity index criteria according to (Brower et al., 1990) are as follows: E < 0,4 = Low level of uniformity; 0,4 ≤ E ≤ 0,6 = Medium level of uniformity; E > 0,6 = High level of uniformity.

Distribution patterns of macrozoobenthos

The distribution pattern of macrozoobenthos was calculated using the calculation method using Morisita formula (Kamalia, 2014) as follows:

$$Id = N \frac{\sum x^2 - \sum x}{(\sum x)^2 - \sum x}$$

Information:

- Id = Type distribution index
- N = Number of sampling plots
- ∑x = Number of individuals per location
- ∑x² = The square of the number of individuals per plot

Assessment criteria based on Kamalia et

al. (2014): Id = 1: Shows a random distribution pattern (R); Id > 1: Shows a clumped or grouped distribution pattern (C); Id < 1: Shows a regular/even uniform distribution pattern (U)

Species Similarity Index

To determine the level of community similarity between the two research stations, macrozoobenthos data were analyzed using the species similarity index:

$$S = \frac{2C}{A+B} \times 100\%$$

Information:

- S = Similarity index
- A = Number of species in location 1
- B = Number of species in location 2
- C = Same number

With the criteria: IS =75-100%: very similar; IS= 50-75% : similar; IS = 25-50% : not similar; IS = ≤ 25% : very unlike

Sedimentary Organic Matter

Organic matter is calculated using the following formula:

$$BO (\%) = \frac{(a - c)}{(a - b)} \times 100 \%$$

Information:

- BO = Organic materials (%)
- a = Weight of cup and sample after temperature drying 105^oC (g)
- b = Cup weight (g)
- c = Weight of the cup and sample after temperature firing 550^oC (g)

Data analysis

The data obtained from sampling are presented in tables and graphs, then discussed descriptively and related to the existing water conditions. The abundance of macrozoobenthos, relative abundance, species diversity (H'), species uniformity (E), distribution patterns, and dominance (D) are processed using Microsoft Excel software to see the differences in macrozoobenthos abundance between stations and zones, and one-way ANOVA statistical tests are carried out.

3. RESULT AND DISCUSSION

General Conditions of Research Locations

South Coast is a Regency in West Sumatra, Indonesia. This regency has an area of 5,749.89 km² and a population of 515,549 in 2021. The capital of the South Coast is in IV Jurai District, precisely in Painan. South Coast

Regency is located on the coast, with a coastline of 218 km. Its topography consists of plains, mountains, and hills, an extension of the Bukit Barisan range. Based on land use, 45.29% of the area consists of forests, including the Kerinci Seblat National Park area, the Koto XI Tarusan Nature Reserve, and peat swamps. South Coast has beautiful and pristine beaches in Nagari Mandeh (Mandeh, 2022).

The Mandeh tourism area covers less than 18,000 ha. This beautiful area combines natural hills with the beauty of the bay, decorated with clusters of small islands located in the middle of Carocok Tarusan Bay. Each island is unique. The islands that can be visited in the Mandeh tourist area are Taraju Island, Setan or Sutan Island, Sironjong Besar Island, Sironjong Ketek Island, Marak Island, and Kapo-Kapo Island. The most famous in foreign countries is Cubadak Island.

The Mandeh area has beautiful

underwater coral reefs and amazing marine biota. About 70 ha of coral reefs are still natural. There is also a 389-ha mangrove forest and various marine biota. With the beauty of the Mandeh Marine National Park, both on land and underwater (marine), the Mandeh tourist area deserves to be called the Paradise of Sumatra, Paradise from West Sumatra (Mandeh, 2022).

Macrozoobenthos Species

The macrozoobenthos species obtained consisted of 2 (two) classes, 5 (five) families, 5 (five) genera, and 9 (nine) species. The macrozoobenthos obtained at all research stations comprised the Gastropoda and Bivalvia classes. The families Cerithiidae, Neritidae, Trochidae, and Cyrenidae. The most common species found at the research location was *Clypeomorus batillariaeformis*. The macrozoobenthos species found can be seen in Table 1.

Table 1. Macrobenthic species found at each observation station on Marapalam Beach

Class	Family	Genus	Species	
Gastropoda	Cerithiidae	Clypeomorus	<i>Clypeomorus batillariaeformis</i>	
		Neritidae	Nerita	<i>Nerita historia</i>
				<i>Nerita polita</i>
			<i>Nerita undata</i>	
			<i>Nerite chamaeleon</i>	
		Trochidae	Monodonta	<i>Monodonta labio</i>
Bivalvia	Potamidae		<i>Tarebralia palustris</i>	
			<i>Tarebralia sulcata</i>	
			<i>Polymesoda erosa</i>	

Abundance of Macrozoobenthos

Calculation of macrozoobenthos abundance at the research location can be seen in Table 2.

Table 2. The abundance of macrozoobenthos on Marapalam Beach

Observation Place	Mean \pm std deviation
Station I	8,44 \pm 1,93
Station II	10,89 \pm 4,49
Station III	11,78 \pm 3,59
Subzone 1	24,33 \pm 2,00
Subzone 2	6,33 \pm 5,55
Subzone 3	0,78 \pm 0,69

The highest abundance was found at Station III, where the abundance was 11.78 ind/m², while the lowest was found at Station I, with an abundance of 8.44 ind/m². The standard deviation value determines whether the data

obtained is accurate and how close it is to the mean value. The smaller the standard deviation value, the more precise the data is and the closer it is to the mean value.

The results of the calculation of the abundance of macrozoobenthos have varying values at each station. The average value of the abundance of macrozoobenthos at Marapalam Beach is 6.85 ind/m². Based on the one-way ANOVA statistical test results at each station, there was a significant difference in the abundance of macrozoobenthos between stations. The probability of significance obtained from the results of the Anova test obtained a p-value of 0.046 < 0.05. Furthermore, a further LSD test was carried out to see the location of the significant difference. Based on the further LSD test, the location of the significant difference in the abundance of macrozoobenthos was obtained, namely

between Station I and Station III, between Station II and Station III, and between Station III.

Cointegration Test

The following step is to identify a long-run equilibrium, for which the Johansen cointegration test is used (see Table 4). The findings of the cointegration test show a long-term equilibrium relationship among the investigated variables. The FMOLS cointegration regression test was then performed to examine the long-term relationship.

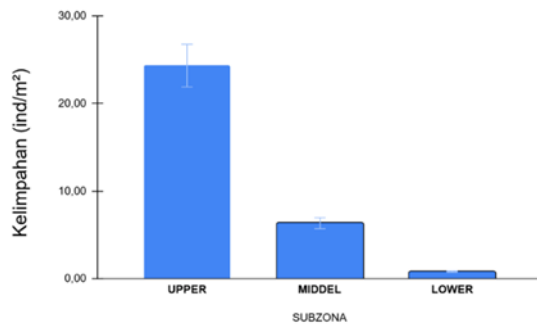

Figure 3. Average (\pm standard deviation) of each abundance between subzones

Based on Figure 3, it can be seen that the calculation results of the abundance of macrozoobenthos in each subzone have varying values. The average value of the abundance of macrozoobenthos in each subzone at Marapalam Beach is 9.23 ind/m². Differences in the abundance of abstract macrozoobenthos in subzones with the ANOVA test. Furthermore, based on the On Way Anova statistical test results, a p-value of 0.042 < 0.05 was obtained, meaning that there was no significant difference in the abundance of macrozoobenthos in each subzone. The probability of significance obtained from the results of the Anova test is 0.042. The abundance of macrozoobenthos in each subzone is significantly different, so a further LSD test was carried out to obtain the location of significant differences in the abundance of macrozoobenthos, namely between Station I and Station III subzones, as well as between Station III and Station I.

Relative Abundance

The results of the relative abundance analysis at the research location on Marapalam Beach can be seen in Table 3.

Table 3. Relative abundance

Types found	Transect			Total	Average Relative Abundance (%)
	1	2	3		
<i>Clypeomorus batillariaeformis</i>	32.89	53.06	1.89	87.84	29.28
<i>Monodonta labio</i>	2.63	2.04	1.89	6.56	2.19
<i>Nerita historia</i>	17.11	13.27	0.00	30.37	10.12
<i>Nerita polita</i>	13.16	10.20	9.43	32.80	10.93
<i>Nerita undata</i>	1.32	2.04	1.89	5.24	1.75
<i>Nerita chamaeleon</i>	27.63	10.20	0.00	37.84	12.61
<i>Polymesoda erosa</i>	3.95	5.10	0.00	9.05	3.02
<i>Tarebralia sulcata</i>	0.00	0.00	36.79	36.79	12.26
<i>Tarebralia palustris</i>	1.32	4.08	48.11	53.51	17.84
Amount	100.00	100.00	100.00	300.00	100.00%

The number of individuals caught in Marapalam Beach was 79, with the intention of representing the waters of Marapalam Beach, each representing three different stations.

Macrozoobenthos Community Index

The results of the analysis of the diversity index (H'), dominance index (C), and evenness index (E) vary at each station. The calculation of the diversity index, dominance index, and diversity index can be seen in Table 4.

Table 4. Macrozoobenthos community index

Observation Place	H'	C	E
Station I	1,63	0,23	0,78
Station II	1,51	0,33	0,73
Station III	1,07	0,38	0,60
Research Location	1,91	0,17	0,87

Based on Table 4, it can be seen that the diversity index at Station I is 1.63, Station II is 1.51, and Station III is 1.07. Table 4 also shows that the macrobenthos diversity index at the research location is 1.91. The macrobenthos diversity index at Marapalam Beach, South

Coast Regency, is $1 \leq H' \leq 3$, indicating that the macrobenthos diversity is moderate, productivity is sufficient, the ecosystem conditions at this research location are balanced, and ecological pressure is moderate. The observed diversity index value is lower than that reported in the study (Bai'un et al., 2021).

Table 4 shows that the dominance index at Station I is 0.23, the dominance index at Station II is 0.33, and the dominance index at Station III is 1.14. The dominance index criteria range from 0-2, and the macrobenthos dominance index at the research location is 0.17. The macrobenthos dominance index of Marapalam Beach waters, $C < 0.3$, indicates that no type of macrobenthos dominates at the research location. Based on the Simpson dominance index, the calculation result < 1 means that the species is highly dominant by another species in the community (Rijaluddin et al., 2017). The low value of the dominance index is due to the absence of dominance of the number of macrozoobenthos species over other

species.

Based on Table 4, it is known that the uniformity index at Station I is 0.78, at Station II is 0.73, and at Station III is 0.60. Table 4 also shows that the uniformity index at Marapalam Beach is 0.87. The uniformity index at Marapalam Beach is $E > 0.6$, which means that the uniformity index at Marapalam Beach is high. A high uniformity index indicates that there is a stable community. This is due to the even distribution of macrobenthos individuals so that no type of macrobenthos dominates at each station (Hamzah, 2022).

Water Quality Parameters

The parameters measured include physical parameters (temperature, brightness, and salinity) and chemical parameters (pH and dissolved oxygen). The aim of measuring these parameters is to determine the condition of the waters at Marapalam Beach. The results of water quality measurements can be seen in Table 5.

Table 5. Measurement of water quality in the waters of Marapalam Beach

Parameter	Station			Quality Material
	I	II	III	
Temperature (°C)	34	30	30	25-36
Salinity	31	30	26	18-32
pH	6	7,3	7,64	18-32
DO	7,2	6	7,8	>5

Table 6. Average \pm standard deviation of sediment organic matter (%) at each observation station on Marapalam Beach

Station	Plot 1 (%)	Plot 2 (%)	Plot 3 (%)	Mean \pm Standard Deviation
I	1,37	4,18	2,45	2,69 \pm 1,67
II	7,28	24,69	14,11	15,36 \pm 7,16
III	53,15	40,36	40,01	44,51 \pm 6,11

Based on Table 6, it can be seen that the percentage of organic matter content in sediment at Marapalam Beach obtained an average value at Station I, namely 2.69%; Station II, namely 15.36%; and Station III, namely 44.51%. The highest organic matter content in sediment was found at Station III, namely 53.15%, while the lowest was found at Station I, 2.69%. The standard deviation value of the three research stations was relatively small, so the data obtained was quite accurate. This value represents all data for each station.

The results of the analysis of sediment

fractions at each research station in the waters of Marapalam Beach consisted of 4 (four) types of sediment fractions, namely gravel, gravelly sand, sandy mud, and muddy sand. The percentage weight of the fraction and type of sediment are presented in Table 7.

Based on Table 7, it can be seen that the type of sediment analyzed using Sheppard's triangle is the type of sediment in the waters of Marapalam Beach dominated by gravel sediment types; the highest percentage is at Station I plot 1, namely 83.56% and the lowest rate is at Station III plot 1, namely 1.47%.

Table 7. Percentage of sediment fraction (%) and sediment type at each research station on Marapalam Beach

Station	Plot	Average Sediment Fraction (%)			Sediment type
		Gravel	Sand	Mud	
I	1	83,65	12,48	3,87	Gravel
	2	80,53	14,39	5,07	Gravel
	3	81,80	13,39	4,81	Gravel
II	1	53,79	26,61	19,61	Sandy Gravel
	2	52,00	27,63	20,36	Sandy Gravel
	3	50,65	27,27	22,08	Sandy Gravel
III	1	1,47	55,95	42,58	Mud Sand
	2	2,79	45,49	51,72	Sandy Mud
	3	2,99	28,88	68,13	Sandy Mud

Distribution Pattern

The value of the species distribution pattern in the intertidal zone of Marapalam Beach waters at Station I is 2.01, Station II is 4.20, and Station III is 5.31. Overall, the species distribution pattern value obtained at the research location is 5.51. The distribution pattern in the intertidal zone of Marapalam Beach waters, $Id > 1$, indicates a clumped or grouped distribution pattern. This can be seen in Table 8.

Table 8. Distribution patterns of macrozoobenthos

Observation Place	Id	Distribution Pattern
Station I	2,01	Grouping
Station II	4,20	Grouping
Station III	5,31	Grouping
Research Location	5,51	Grouping

Similarity index of Species

The similarity index value of macrozoobenthos species in the intertidal zone of Marapalam Beach waters, namely Station I to II, is 100%, Station I to III and Station II to III are 71%, which shows that the type of macrozoobenthos community is very high. Can be seen in Table 9.

Table 9. Similarity index of macrozoobenthos types

Station	Similarity index type (%)	Similarities
I To II	100	Same
I To III	71	Same as same
II To II	71	Same as same

Based on Table 9, the species similarity index is used to compare between observation zones. Calculating the similarity index between two zones. The results of calculating the Similarity of macrozoobenthos. Based on the analysis of the species similarity index, there are different values of macrozoobenthos species similarity found in each research zone, ranging from 71.00-100.00%, which is categorized as having a very high similarity index. Factors that influence the high species similarity index between all zones are the type of mangrove forest and the location of the research site, whose environmental factors are not much different and are close to the river mouth, so they are still affected by the same ebb and flow of water.

4. CONCLUSION

The observation results obtained 2 (two) classes of gastropods and bivalves, 5 (five) families Cerithidae, Neritidae, Trochidae, Potamidae, and Cyrenidae, 5 (five) genera *Clypeomorus*, *Nerita*, *Monodonta*, *Terebralia*, and *Polymesoda*, 9 (nine) species of macrozoobenthos consisting of *Clypeomorus batillariaeformis*, *Nerita historia*, *N. polita*, *N. undata*, *N. chamaeleon*, *Monodonta labio*, *Polymesoda erosa*, *Terebralia paulustris*, and *T. sulcata*.

The abundance of macrozoobenthos in the intertidal zone at Marapalam Beach ranges from 8.44-11.78 ind/m². The highest relative abundance at the research location is found in the species *C. batillariaeformis*. The diversity of the research location with a value ($H' 1.19$) indicates that the diversity of macrozoobenthos at Marapalam Beach is in the moderate category. The dominance of the research location with a dominance value ($C 0.17$) suggests that no type

of macrozoobenthos dominates the research location. The uniformity of the research location with a uniformity value (E 0.87) indicates that the uniformity at the research location is high.

The distribution pattern of

macrozoobenthos at the intertidal zone research location at Marapalam Beach is clumped or grouped (Id 5.51). The similarity index, among others, is 71-100%, categorized as high type similarity.

REFERENCES

- Afif, J.N.S., & Pribadi, T.A. (2014). Keanekaragaman Makrozobenthos Sebagai Indikator Kualitas Perairan di Ekosistem Mangrove Wilayah Tapak kelurahan Gurejo Kota Semarang. *Unnes Journal of Life Science*, 3(1): 47- 52.
- Alwi, D. (2020). Keanekaragaman dan Kelimpahan Makrozoobenthos pada Ekosistem Mangrove Desa Daruba Pantai Kabupaten Pulau Morotai. *Journal Enggano*, 5(1): 64-77.
- Bai'un, N.H., Riyantini, I., Mulyani, Y., & Zallesa, S. (2021). Keanekaragaman Makrozoobentos sebagai Indikator Kondisi Perairan di Ekosistem Mangrove Pulau Pari, Kepulauan Seribu. *Journal of Fisheries and Marine Research*, 5(2): 227-238.
- Brower, J.E., Zar, J. H., & Von Ende, C.N. (1998). *Field and Laboratory Methods for General Ecology*. Boston: WCB McGraw-Hill.
- Carpenter, K.E., & Niem, V.H. (1998). *The Living Marine Resources of the Western Central Pacific*. Volume 1. Seaweeds, corals, bivalves and gastropods (pp. xiv+-686).
- Fachrul, M.F. (2007). *Metode Sampling Bioekologi*. Bumi Aksara. Jakarta.
- Fajri, N. (2013). Struktur Komunitas Makrozoobenthos di Perairan Pantai Kuwang Wae Kabupaten Lombok Timur. *Jurnal Educatio*, 8(2): 81-100.
- Hamzah, S.F., Hamdani, H., & Astuty, S. (2022). Struktur Komunitas Makrozoobentos di Kawasan Ekowisata Hutan Mangrove Pandansari, Brebes, Jawa Tengah. *Jurnal Kelautan Nasional*, 17(1): 1-12.
- Kamalia, M., Raza'i, T.S., & Zulfikar, A. (2014). *Pola Sebaran Gastropoda di Ekosistem Mangrove Kelurahan Tanjung Ayun Sakti Kecamatan Bukit Bestari Kota Tanjung Pinang*. Fakultas Ilmu Kelautan dan Perikanan. Universitas Maritim Raja Ali Haji. Tanjung Pinang.
- Mandeh, N. (2022) Kawasan Mandeh Objek Wisata. <https://mandeh.pesisirselatankab.go.id/artikel/2022/2/10/kawasan-mandeh-objek-wisata-yang-terbaik>.
- Odum, E.P. (1993). *Dasar-Dasar Ekologi*. Gadjah Mada University Press. Yogyakarta. 574 p.
- Pemerintah Indonesia. (2014). Undang-Undang No. 1 Tahun 2014 tentang Pengelolaan Wilayah Pesisir dan Pulau-Pulau Kecil. Jakarta.
- Ramadani, L. (2019). *Keanekaragaman Makrozoobentos Sebagai biontikator Kualitas Air di Sungai Way Kedamaian Bandar Lampung*. Universitas Islam Negeri Raden Intan Lampung. Lampung.
- Ridwan, M., Fathoni R, Fatihah, I., & Pangestu, D.A. (2016). Struktur Komunitas Makrozoobentos di Empat Muara Sungai Cagar Alam Pulau Dua, Serang, Banten. *Al-Kaunyah Journal Biologi*, 9(1): 57-65.
- Rijaluddin, A.F., Wijayanti, F., & Haryadi, J. (2017). Struktur Komunitas di Situ Ginting, Situ Bungur dan Situ Kuru, Ciputat Timur. *Journal Teknologi Lingkungan*, 18(2): 139-147.
- Rizkya, S., Rudiyananti, S. & Muskananfolo, M.R. (2012). Studi Kelimpahan Gastropoda (*Lambis* Spp.) pada Daerah Makroalga di Pulau Pramuka, Kepulauan Seribu. *Journal of Management of Aquatic Resources*, 1(1): 1- 7.
- Setiawan, J., & Maulana, F. (2019). Keanekaragaman Jenis Arthropoda Permukaan Tanah di Desa Banua Rantau Kecamatan Banua Lawas. *Journal Pendidikan Hayati*, 5(1): 39-45.
- Tobing, I.S.L. (2009). Kondisi Perairan Pantai sekitas Merak, Banten Berdasarkan Indeks Keanekaragaman Jenis Benthos. *Journal Fakultas Biologi Universitas Nasional Jakarta*, 2(2): 31-40.

Zulfa, U. (2015). *Keanekaragaman Jenis Asteroidea di Zona Intertidal Pantai Pancur Taman Nasional Alas Purwo*. Universitas Jember